

AODF Specifications 声光偏转器产品规格书 DF1015-TL085_40-030-1064

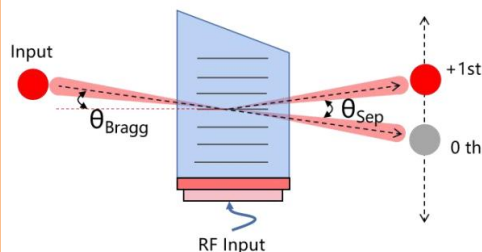

1. SPECIFICATIONS (规格)

Interaction material (介质材料)	Tellurium dioxide (二氧化碲)
Acoustic mode (声波模式)	Longitudinal (纵波)
Operating wavelength (工作波长)	1064nm
Polarization (光偏振)	Linear, perpendicular to base (线偏振, 垂直于基座)
Transmission (透过率)	> 99%
Active aperture (有效孔径)	3.0mm
Center frequency (Fc) (中心频率)	85MHz
RF bandwidth (RB) (射频带宽)	40MHz
Diffraction efficiency (衍射效率) @RB	> 80%
RF power (射频功率)	4 W (max)
Input Impedance (输入阻抗)	50Ω Nominal
VSWR (驻波比) @Fc	< 2.1:1
RF connector (射频接头)	SMA-F
Cooling (散热方式)	Water-cooling (水冷散热)
Shell material (外壳材料)	Aluminum alloy (铝合金)
Water cooling channel material (水冷块材料)	Aluminum alloy (铝合金)

2. PERFORMANCE vs. WAVELENGTH (性能 vs. 波长)

Wavelength (光波长)	1064 nm
Bragg angle (布拉格角) @Fc	10.6. mrad
Separation angle (分离角) @Fc	21.2mrad
Scan angle (扫描角度) @RB	10.0mrad

3. ORDERING CODES (编码规则)

	Fc	RB	Active aperture	Wavelength
DF0001— TL	XXX	XXX	XXX	XXXX
27.12 MHz	027	010	10 MHz	040 4 mm 266 266 nm
40.68 MHz	041	050	50 MHz	060 6 mm 355 355 nm
80 MHz	080	080	80 MHz	080 8 mm

4. DIMENSIONS (外形尺寸-mm)

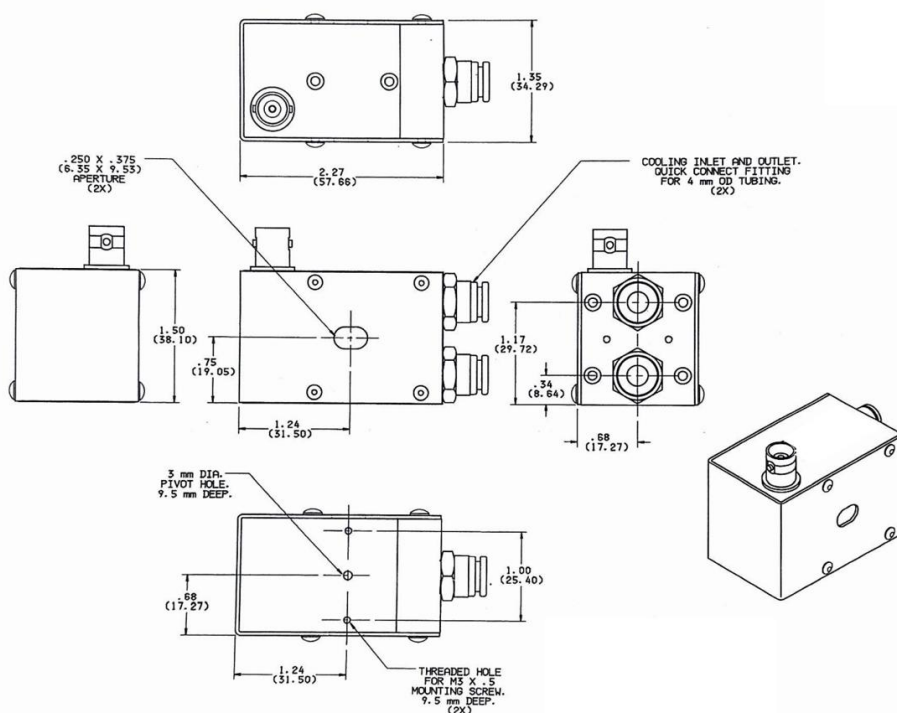

5. SUGGESTED RF DRIVER ELECTRONICS (建议驱动型号)

RB1013-085_40-24-004-CT

6. REVISION (版本)

Number (版本号)	Revisions date (修订日期)	Revision (修改项目)	Revision description (修订内容说明)
A	2024. 5. 13	New	/

Quality Assured: In house made, high damage threshold, Vacuum bonding, 100% Diffraction efficiency test & burn-in test.